

EE 435

Lecture 13

Cascaded Amplifiers

Two-Stage Op Amp Design

Review of Basic Concepts

Review from Last Time

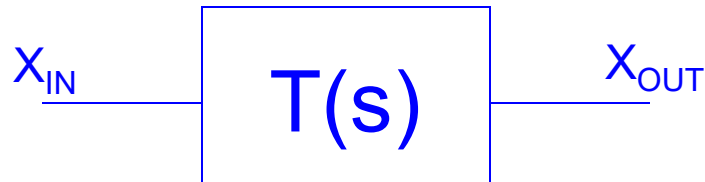

If $T(s) = \frac{N(s)}{D(s)}$ is the transfer function of a linear system

Roots of $N(s)$ are termed the zeros

Roots of $D(s)$ are termed the poles

Theorem: A linear system is stable iff all poles lie in the open left half-plane

- If a circuit is unstable, the output will either diverge to infinity or oscillate even if the input is set to 0
- A FB amplifier circuit that is not stable is not a useful “stand alone” FB amplifier
- A FB amplifier circuit that is “close” to becoming unstable is not a useful “stand alone” amplifier
- An amplifier circuit that exhibits excessive ringing or gain peaking is not a useful “stand alone” amplifier

Routh-Hurwitz Stability Criteria:

A third-order polynomial $s^3+a_2s^2+a_1s+a_0$ has all poles in the LHP iff all coefficients are positive and $a_1a_2>a_0$

- Very useful in amplifier and filter design
- Can easily determine if poles in LHP without finding poles
- But tells little about how far in LHP poles may be
- RH exists for higher-order polynomials as well

Cascaded Amplifier Issues

For identical first-order lowpass stage gains $A = \frac{A_0 \tilde{p}}{s + \tilde{p}}$

Summary:

- Three amplifier cascades - for ideally identical stages $8 > \beta A_0^3$
 - seldom used in industry though some recent products use this method !
 - invariably modify A
- Four or more amplifier cascades - problems even larger than for three stages
 - seldom used in industry !

Consider now two amplifiers in cascade

Review from Last Time

Two-stage Cascade (continued)

$$D_{FB}(s) = s^2 + s\tilde{p}_1(1+k) + k\tilde{p}_1^2(1+\beta A_{0TOT})$$

$$A_1 = \frac{A_{01} \tilde{p}_1}{s + \tilde{p}_1}$$

$$A_2 = \frac{A_{02} k \tilde{p}_1}{s + k\tilde{p}_1}$$

$$A_{OL} = \prod_{i=1}^2 A_k$$

k is the open-loop pole spread

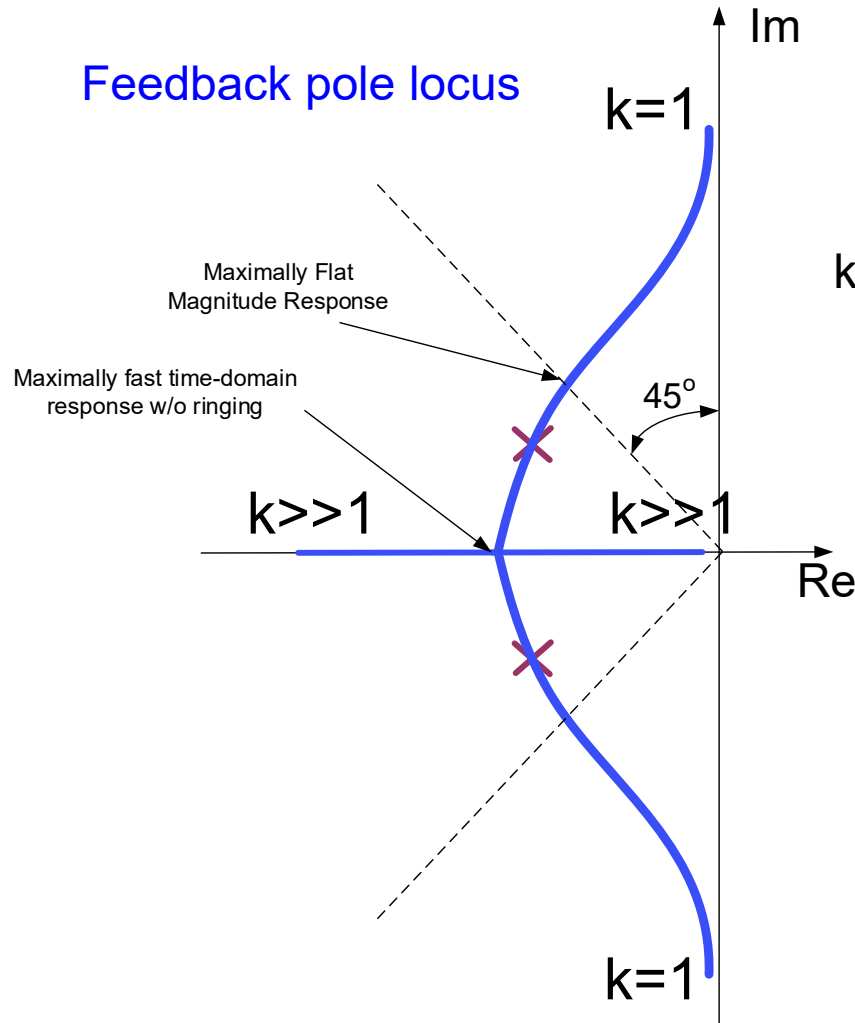

Will be shown that maximally flat response for second-order all-pole amplifier occurs with $\theta=45^\circ$ and maximally fast step response w/o ringing occurs with $\theta=90^\circ$

Review of Basic Concepts

Review from Last Time

Consider a second-order factor of a denominator polynomial, $P(s)$, expressed in integer-monic form

$$P(s) = s^2 + a_1s + a_0$$

Then $P(s)$ can be expressed in several alternative but equivalent ways

$$s^2 + s \frac{\omega_0}{Q} + \omega_0^2$$

$$s^2 + s2\zeta\omega_0 + \omega_0^2$$

$$(s - p_1)(s - p_2)$$

if real – axis poles

$$(s - p_1)(s - kp_1)$$

and if complex conjugate poles,

$$(s + \alpha + j\beta)(s + \alpha - j\beta)$$

$$(s + re^{j\theta})(s + re^{-j\theta})$$

Widely used alternate parameter sets:

$$\{ (a_1, a_2) (\omega_0, Q) (\omega_0, \zeta) (p_1, p_2) (p_1, k) (\alpha, \beta) (r, \theta) \}$$

These are all 2-parameter characterizations of the second-order factor and it is easy to map from any one characterization to any other

Review from Last Time

Review of Basic Concepts

$$s^2 + s\tilde{p}_1(1+k) + k\tilde{p}_1^2(1+\beta A_{0TOT}) \quad \Rightarrow \quad s^2 + s\frac{\omega_0}{Q} + \omega_0^2$$

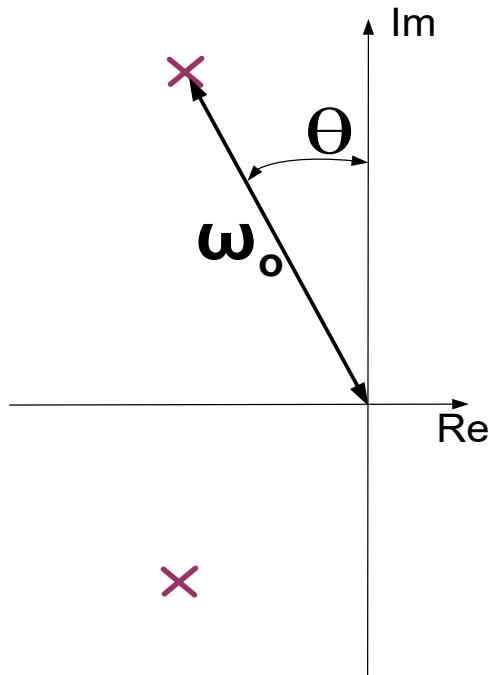

$$\sin\theta = \frac{1}{2Q}$$

ω_0 = magnitude of pole

Q determines the angle of the pole

Observe: $Q=0.5$ corresponds to two identical real-axis poles
 $Q=.707$ corresponds to poles making 45° angle with Im axis

Review from Last Time

Two-stage Cascade (continued)

$$D_{FB}(s) = s^2 + s\tilde{p}_1(1+k) + k\tilde{p}_1^2(1+\beta A_{0TOT})$$

Alternate notation for $D_{FB}(s)$

$$D_{FB}(s) = s^2 + s\frac{\omega_0}{Q} + \omega_0^2$$

or

$$D_{FB}(s) = s^2 + s2\xi\omega_0 + \omega_0^2$$

$$\omega_0 = \tilde{p}_1\sqrt{k(1+\beta A_{0TOT})} \cong \tilde{p}_1\sqrt{k\beta A_{0TOT}}$$

$$\frac{\omega_0}{Q} = \tilde{p}_1(1+k)$$

Thus it follows that

$$Q = \frac{\sqrt{k}}{(1+k)}\sqrt{\beta A_{0TOT}}$$

$$\xi = \frac{1}{2Q}$$

Feedback pole locus

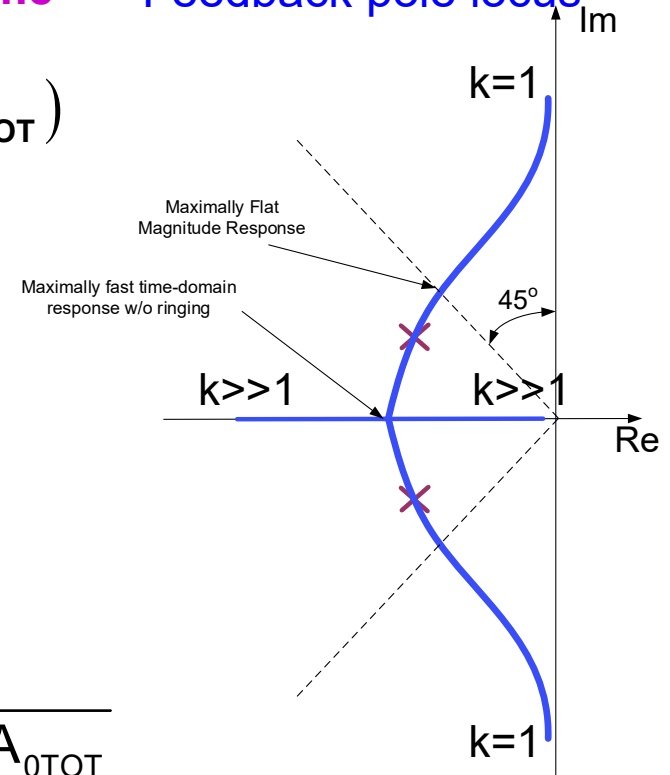

Assume β is fixed

Review from Last Time

Magnitude Response of 2nd-order all-pole (Low-pass) Function

$$Q = \frac{1}{2\xi}$$

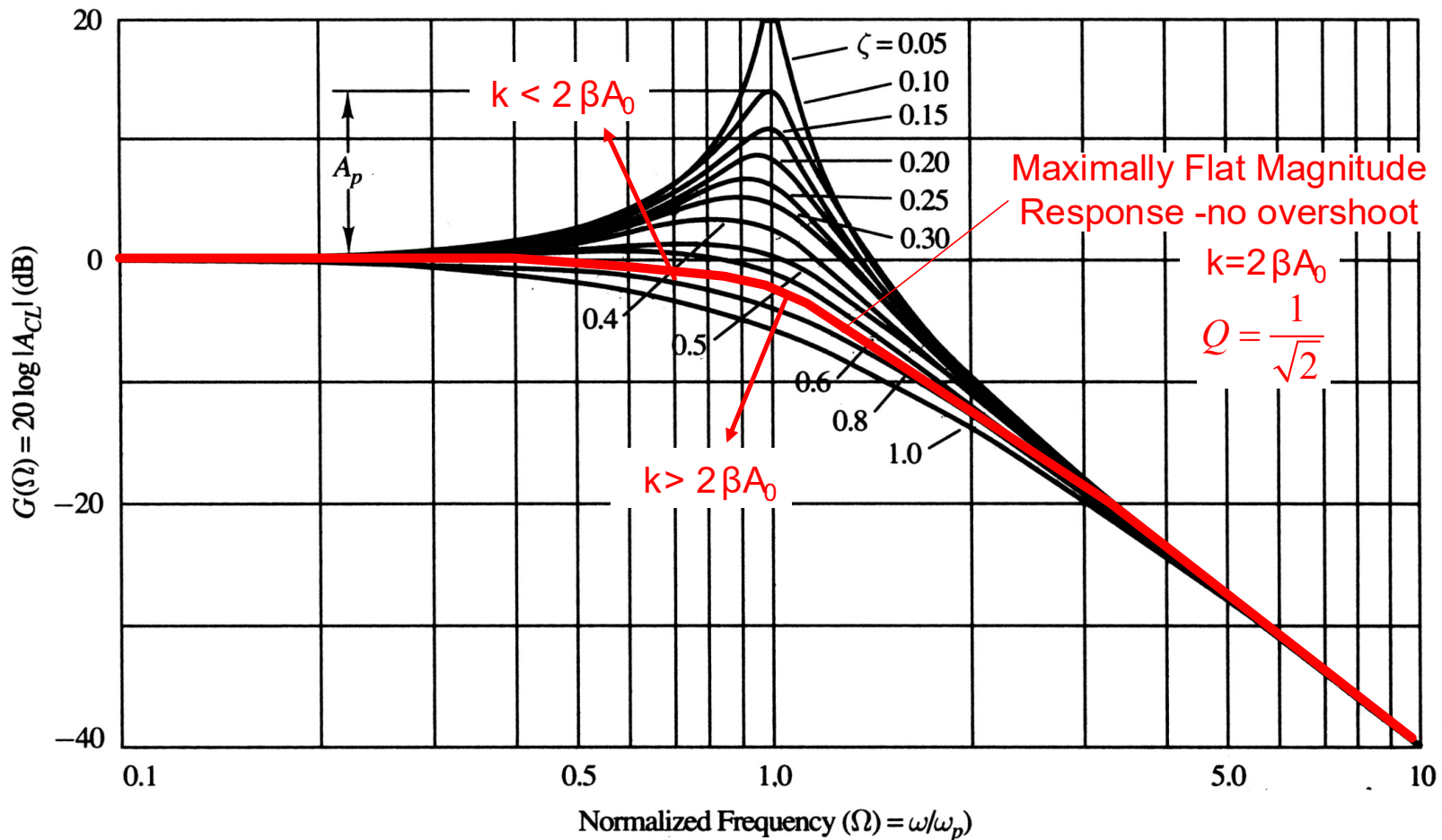

From Laker-Sansen Text

For two-stage all-pole amplifiers, must have open-loop pole spread, k , very large to avoid overshoot in closed-loop gain

Review from Last Time

Step Response of 2nd-order all-pole (Low-pass) Function

$$Q = \frac{1}{2\xi}$$

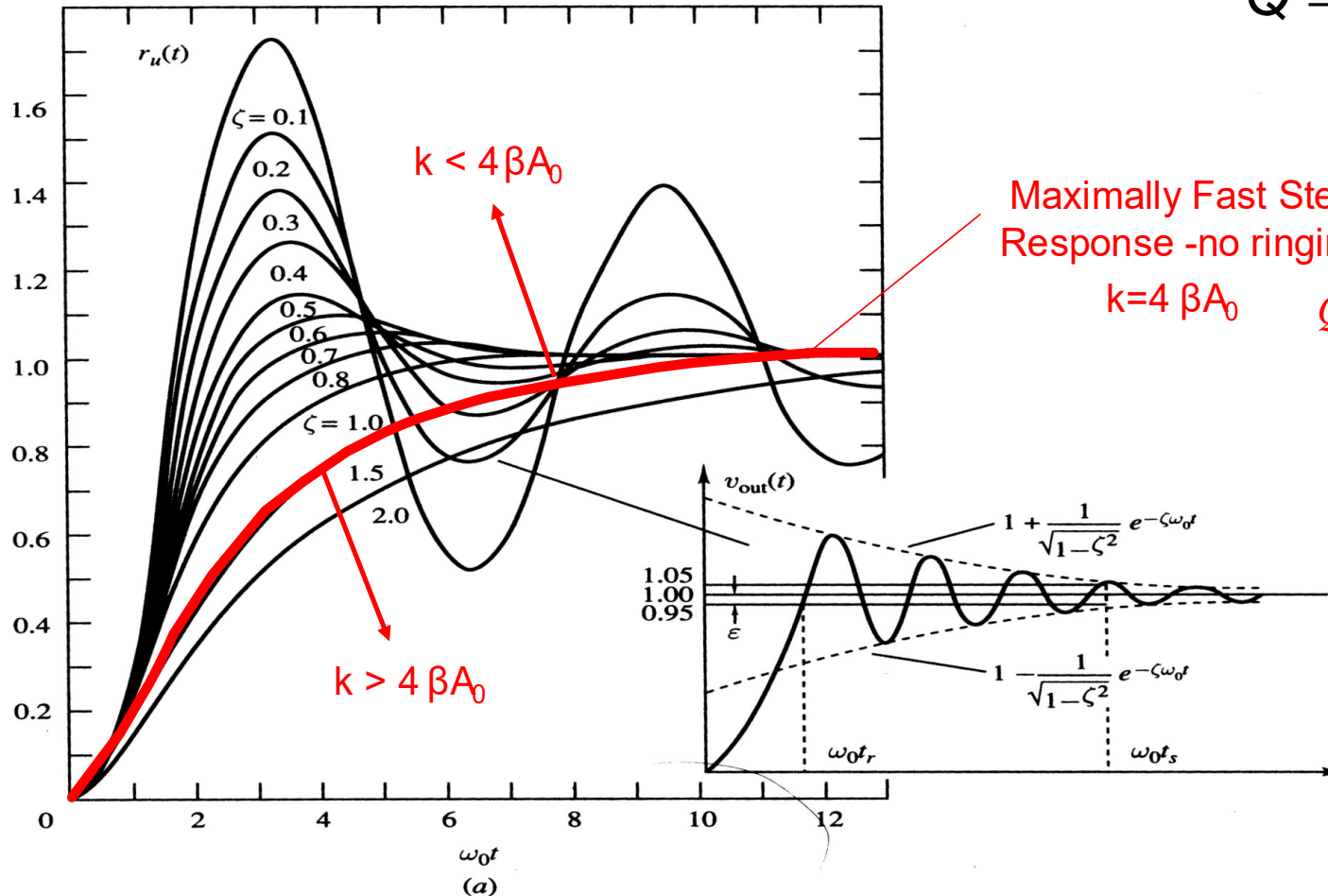

Q_{MAX} for no overshoot = 1/2

From Laker-Sansen Text

For two-stage amplifiers, must have open-loop pole spread, k , very large to avoid ringing in step response

Two-stage Cascade second-order (continued)

$$D_{FB}(s) = s^2 + s\tilde{p}_1(1+k) + k\tilde{p}_1^2(1+\beta A_{0TOT})$$

Alternate notation for $D_{FB}(s)$

$$D_{FB}(s) = s^2 + s\frac{\omega_0}{Q} + \omega_0^2$$

Typically design open loop amplifier so

$$\frac{1}{2} < Q < \frac{1}{\sqrt{2}}$$

Because

if $Q > \frac{1}{\sqrt{2}}$ overshoot and ringing unacceptable

If $Q < \frac{1}{2}$ rise time too slow and closed-loop BW is reduced

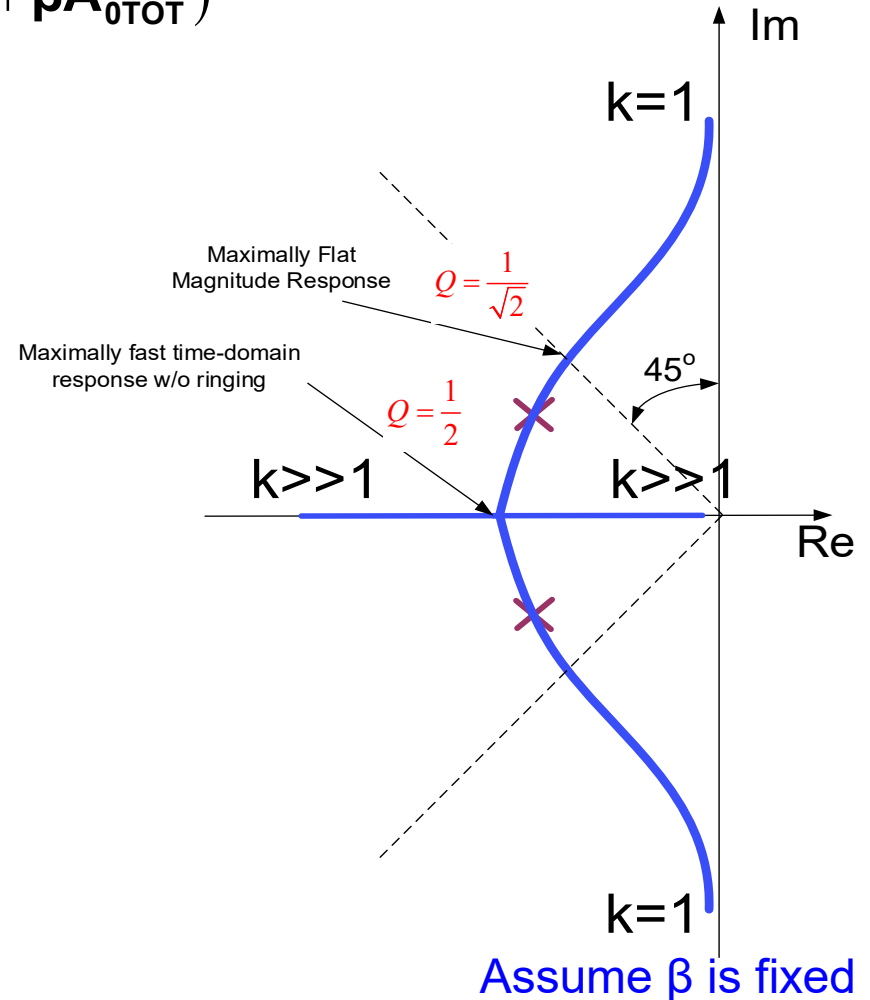

Two-stage Cascade second-order (continued)

$$D_{FB}(s) = s^2 + s\tilde{p}_1(1+k) + k\tilde{p}_1^2(1+\beta A_{0TOT})$$

$$D_{FB}(s) = s^2 + s\frac{\omega_0}{Q} + \omega_0^2$$

Typically design open loop amplifier so

$$\frac{1}{2} < Q < \frac{1}{\sqrt{2}}$$

So, what is the open-loop pole spread?

$$Q = \frac{\sqrt{k}}{(1+k)} \sqrt{\beta A_{0TOT}} \underset{k \text{ large}}{\approx} \sqrt{\frac{\beta A_{0TOT}}{k}}$$

$$k = \frac{\beta A_{0TOT}}{Q^2}$$

Thus, it follows amplifiers are usually designed so that

$$4\beta A_{0TOT} > k > 2\beta A_{0TOT}$$

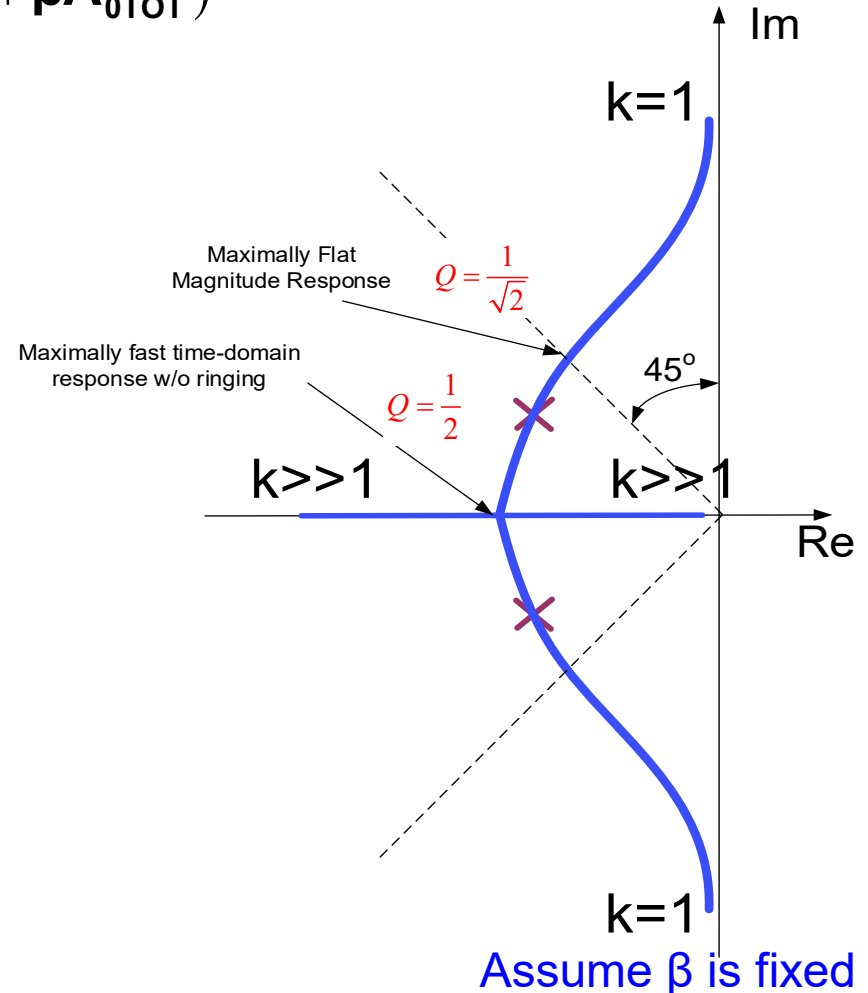

Typical Target Closed-loop Pole Locations for Feedback Amplifiers

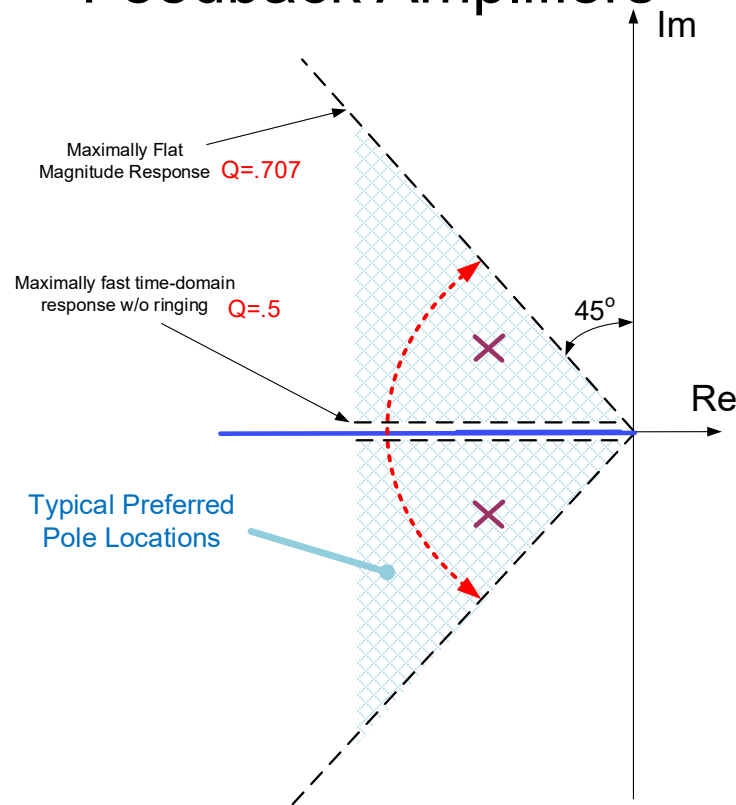

- For two-stage all-pole amplifiers, must have open-loop pole spread, k , very large to obtain desired performance of feedback amplifier
- Cascading of two identical amplifier stages to increase op amp gain not practical
- Two-stage amplifiers widely used to build op amps but must manage pole spreads (even if not all-pole) - this will be discussed in detail when on the topic of compensation

Determination of open-loop pole spread, k , for acceptable feedback performance

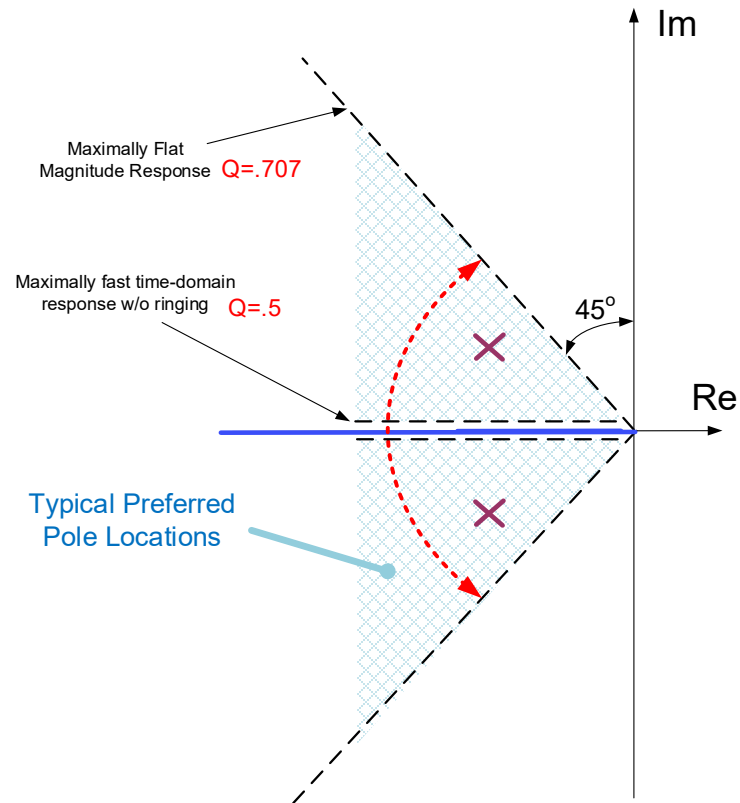

Determination of desired open-loop pole spread, k ,

Two-stage Cascade second-order all pole

$$A_1 = \frac{A_{01} \tilde{p}_1}{s + \tilde{p}_1}$$

$$D_{FB}(s) = s^2 + s\tilde{p}_1(1+k) + k\tilde{p}_1^2(1+\beta A_{0TOT}) \quad \tilde{p}_2 = k\tilde{p}_1 \quad A_2 = \frac{A_{02} \tilde{p}_2}{s + \tilde{p}_2} = \frac{A_{02} k\tilde{p}_1}{s + k\tilde{p}_1}$$

From quadratic equation (for k large and $\beta A_{0TOT} \gg 1$) obtain:

$$p_{1F,2F} \cong \frac{\tilde{p}_1}{2} \left(-k \pm j\sqrt{4A_{0TOT}k\beta - k^2} \right) \quad Q = \frac{\sqrt{k}}{(1+k)} \sqrt{\beta A_{0TOT}} \underset{k \text{ large}}{\cong} \sqrt{\frac{\beta A_{0TOT}}{k}}$$

Or equivalently $k \underset{k \text{ large}}{\cong} \frac{\beta A_{0TOT}}{Q^2}$

Case 1: Identical negative real-axis FB poles (no zeros); must make discriminant 0,

thus

(maximally fast time-domain step response w/o ringing)

$$k \cong 4\beta A_{0TOT} \implies Q = \frac{1}{2}$$

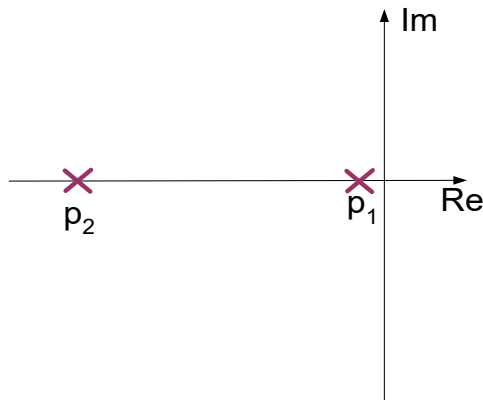

Open Loop

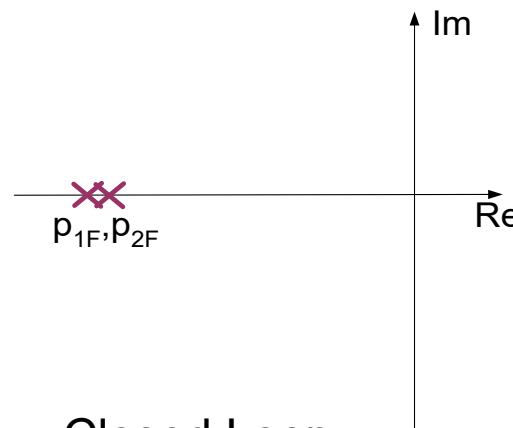

Closed Loop

Determination of open-loop pole spread, k,

Two-stage Cascade second-order all pole (continued)

$$p_{1,2} \cong \frac{\tilde{p}_1}{2} \left(-k \pm j\sqrt{4A_{0TOT}k\beta - k^2} \right)$$

$$\tilde{p}_2 = k\tilde{p}_1$$

$$Q \underset{k \text{ large}}{\cong} \sqrt{\frac{\beta A_{0TOT}}{k}}$$

Case 2: Maximally flat all-pole FB magnitude response; must make real and imaginary parts equal

$$k = \sqrt{4A_{0TOT}k\beta - k^2}$$

$$k \cong 2\beta A_{0TOT}$$

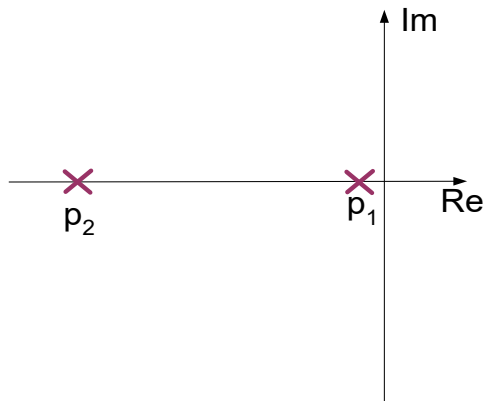
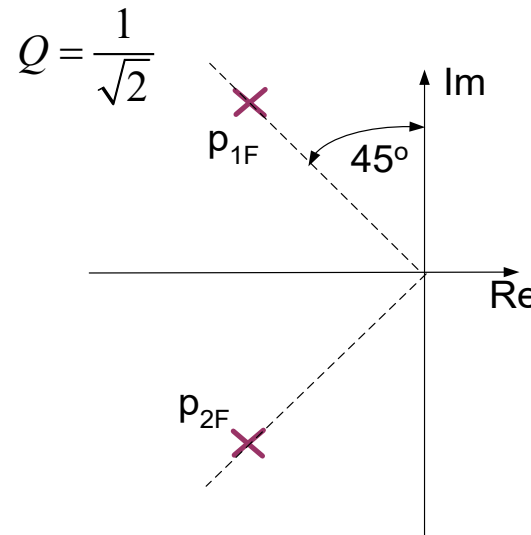

Open Loop

Closed Loop

- Small ringing in step response
- Factor of 2 reduction in pole spread

Determination of open-loop pole spread, k,

Two-stage Cascade second-order all pole(continued)

$$p_{1,2} \cong \frac{\tilde{p}_1}{2} \left(-k \pm j\sqrt{4A_{0TOT}k\beta - k^2} \right) \quad \tilde{p}_2 = k\tilde{p}_1$$

- The pole spread for maximal frequency domain flatness or fast non-ringing time domain step response is quite large for the two-stage amplifier but can be achieved
- Usually will make angle of feedback poles with imaginary axis between 45° and 90°
- This results in an open loop pole spread that satisfies the relationship
$$4\beta A_{0TOT} > k > 2\beta A_{0TOT}$$
- “Compensation” can be viewed as the modification of the pole locations of an amplifier to achieve a desired closed-loop pole angle or pole placement
- “Compensation” should not be considered as a modification of the pole locations to achieve stability since an amplifier is of little use if stability concerns are present

Brief Summary of Operation of cascade of 2 single-pole amplifiers

Pole Locus vs β for 2nd-order Amplifiers

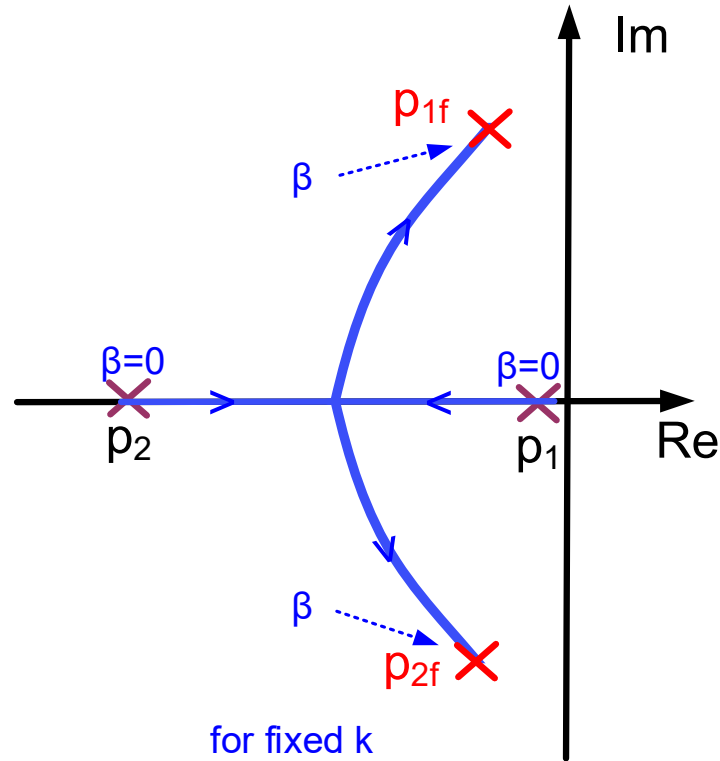

$\beta=0$: open loop poles p_1, p_2

Actual β : closed loop poles p_{1f}, p_{2f}

- Feedback poles strongly dependent upon β
- β large (i.e. $\beta=1$) often most challenging to deal with

Brief Summary of Operation of cascade of 2 single-pole amplifiers

Closed-loop pole Locus vs k for 2nd-order Amplifiers

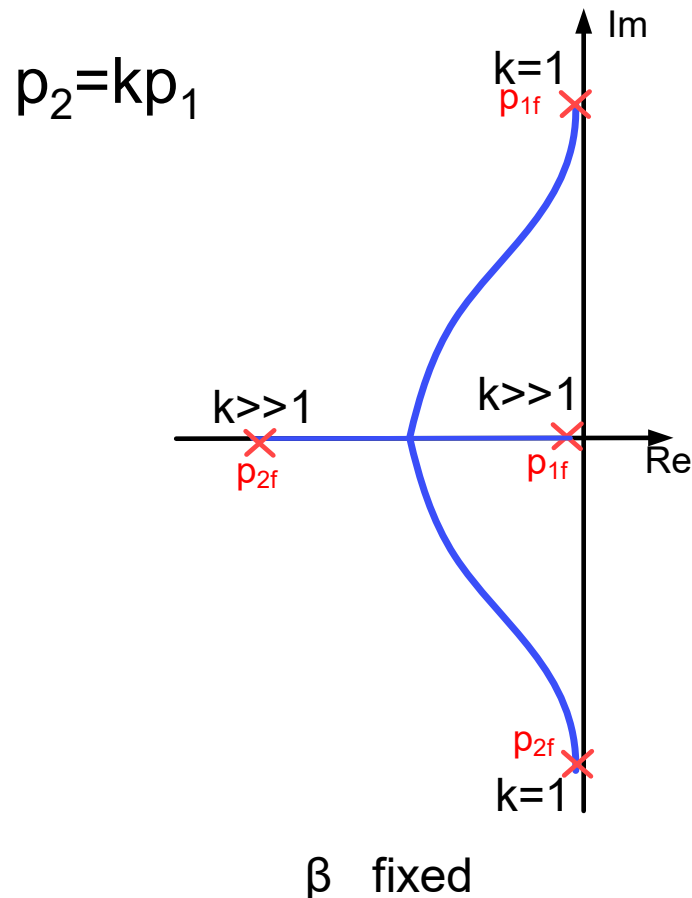

- poles strongly dependent upon open-loop pole spread, k
- k small often most challenging to deal with

Brief Summary of Operation of cascade of 2 single-pole amplifiers

Pole Locus vs β for 2nd-order amplifiers for varying k

$$p_2 = kp_1$$

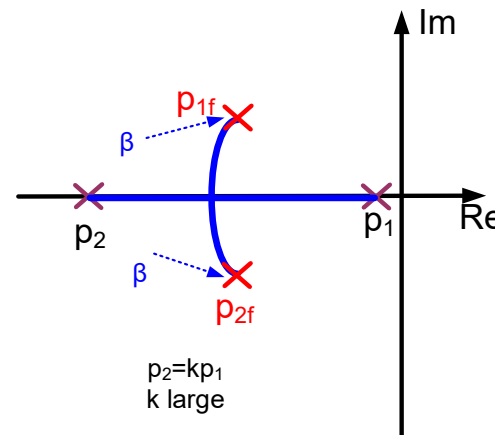
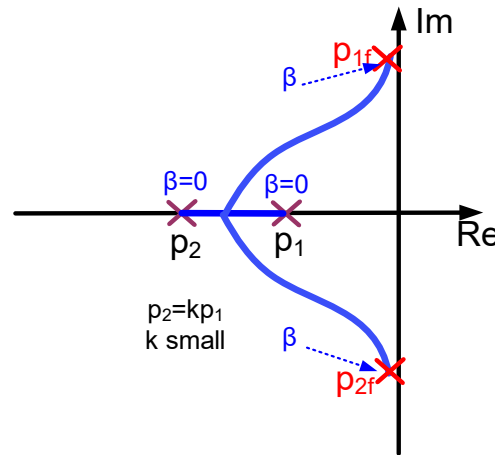

- poles strongly dependent upon open-loop pole spread, k, and β
- k small and β large are often most challenging to deal with

Cascaded Amplifier Summary

$$A_1 = \frac{A_{01} \tilde{p}_1}{s + \tilde{p}_1}$$

$$A_2 = \frac{A_{02} \tilde{p}_2}{s + \tilde{p}_2} = \frac{A_{02} k \tilde{p}_1}{s + k \tilde{p}_1}$$

$$\tilde{p}_2 = k \tilde{p}_1$$

- Single-stage amplifiers
 - widely used in industry, little or no concern about compensation

- Two amplifier cascades – for separated poles $4\beta A_{0TOT} > k > 2\beta A_{0TOT}$
 - (both single pole)
 - widely used in industry but compensation is essential
 - spread dependent upon β and most stringent for large β

- Three amplifier cascades - for ideally identical stages $8 > \beta A_0^3$
 - (all single pole)
 - seldom used in industry !

- Three amplifier cascades - for separated poles
 - (all single pole)
 - $(1 + k_2 + k_3)(k_2 + k_3 + k_2 k_3) > \beta A_{0TOT}$
 - seldom used in industry but starting to appear but compensation essential!

- Four or more amplifier cascades - problems even larger than for three stages
 - seldom used in industry !

Note: Some amplifiers that are termed single-stage amplifiers in many books and papers are actually two-stage amplifiers and some require modest compensation. Some that are termed two-stage amplifiers are actually three-stage amplifiers. These invariably have a very small gain on the first stage and a very large bandwidth. The nomenclature on this summary refers to the number of stages that have reasonably large gain.

Summary of Observations about Cascaded Amplifiers

A cascade of amplifiers can result in a very high dc gain !

Characteristics of feedback amplifier (where the op amp is applied) are of ultimate concern

Some critical and fundamental issues came up with even the most basic cascades when they are used in a feedback configuration

Must understand how open-loop and closed-loop amplifier performance relate before proceeding to design amplifiers by cascading

Summary of Amplifier Characteristics, Concerns, and Objectives

- An amplifier is stable iff all poles lie in the open LHP
- Routh-Hurwitz Criteria is often a practical way to determine if an amplifier is stable
- The cascade of three identical high-gain all-pole amplifiers will result in a pole-pair far in the right half plane when feedback is applied so FB amplifier will be unstable

$$A = \frac{A_0 \tilde{p}}{s + \tilde{p}} \quad A_{FB} = \frac{A}{1 + A\beta} = \frac{A_0^3}{\left(\frac{s}{\tilde{p}} + 1\right)^3 + \beta A_0^3}$$

$$\text{for stability} \quad 8 > \beta A_0^3$$

- Although stability of an amplifier is critical, a good amplifier must not only be stable but generally must satisfy magnitude peaking and/or settling requirements thus poles need to be moved a reasonable distance (in the angular sense) from the imaginary axis
- Designing an amplifier with concerns about stability will likely result in a poor amplifier design, design emphasis should be on more stringent requirements like magnitude peaking, settling, or other closed-loop metrics that are dictated by the intended application

Where we are at:

Amplifier Design

- Fundamental Amplifier Design Issues
- Single-Stage Low Gain Op Amps
- Single-Stage High Gain Op Amps
- Other Basic Gain Enhancement Approaches
 - Cascaded Amplifiers
(will return to this later)
-  Two-Stage Op Amp
 - Compensation
 - Breaking the Loop
- Other Issues in Amplifier Design
- Summary Remarks

Basic Two-Stage Cascade

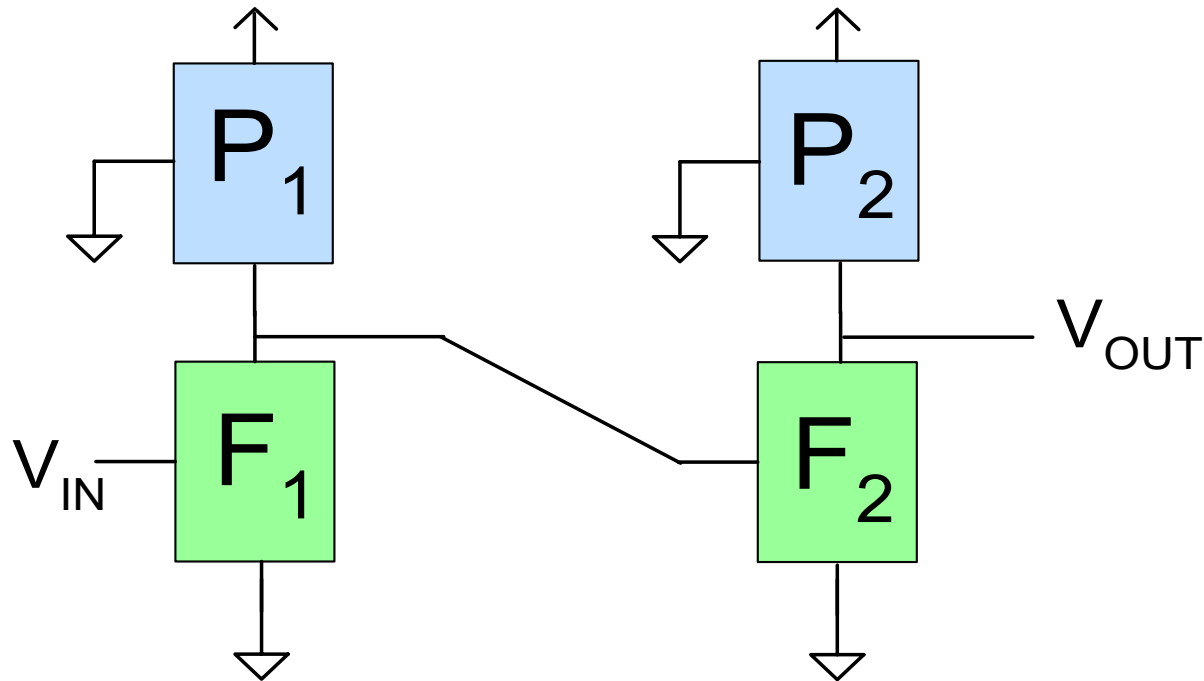

Can be extended to fully differential on first and/or second stage

- Simple Concept
- Several variants of basic cascade concept
- Must decide what to use for the two quarter circuits

Basic Two-Stage Cascade

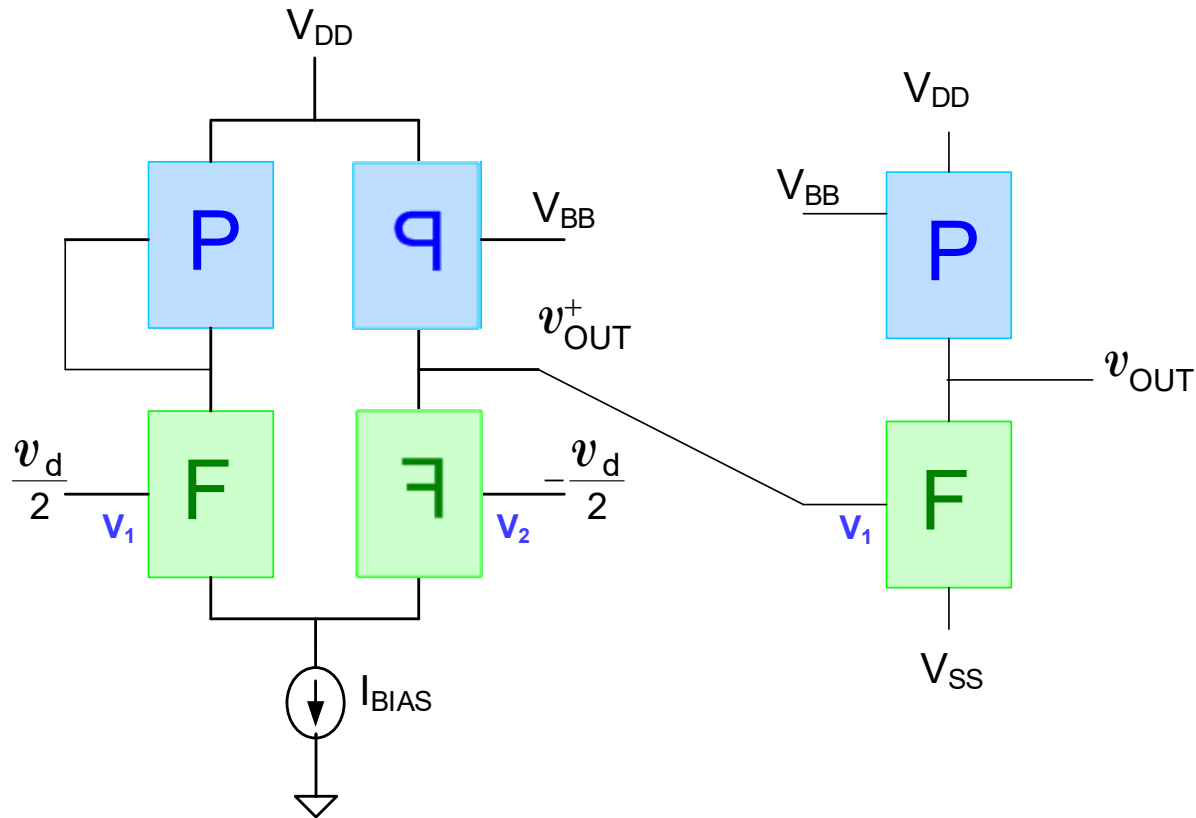

- Widely used structure for single-ended output
- Quarter circuits often different between first stage and second stage

Basic Two-Stage Cascade

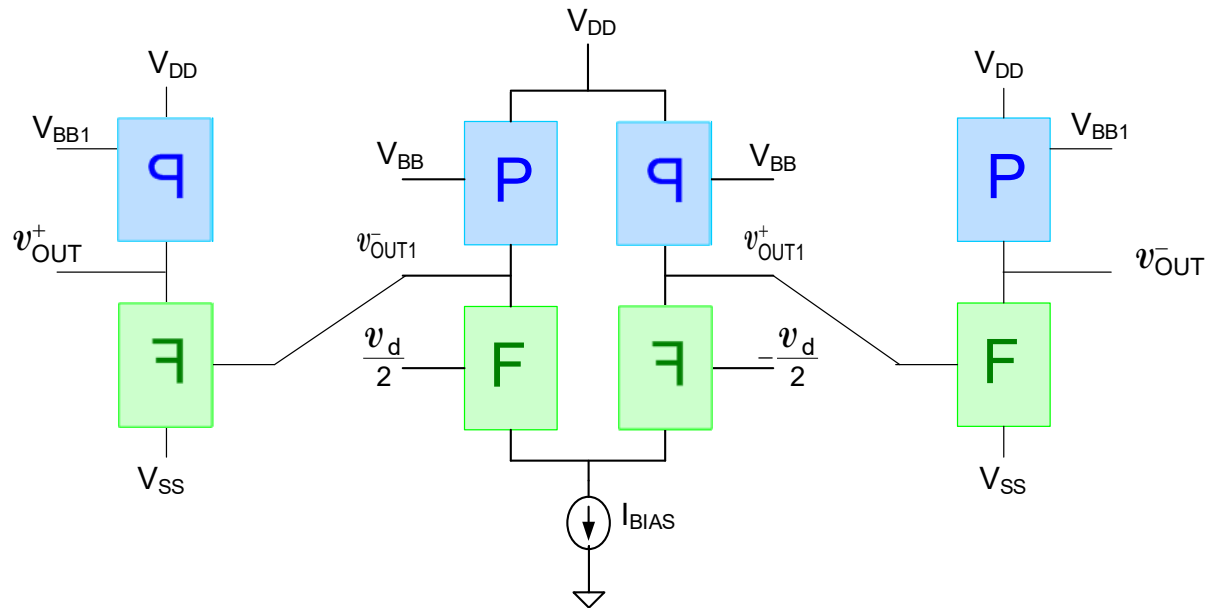

- Widely used structure for differential outputs
- Quarter circuits often different between first stage and second stage

Basic Two-Stage Cascade

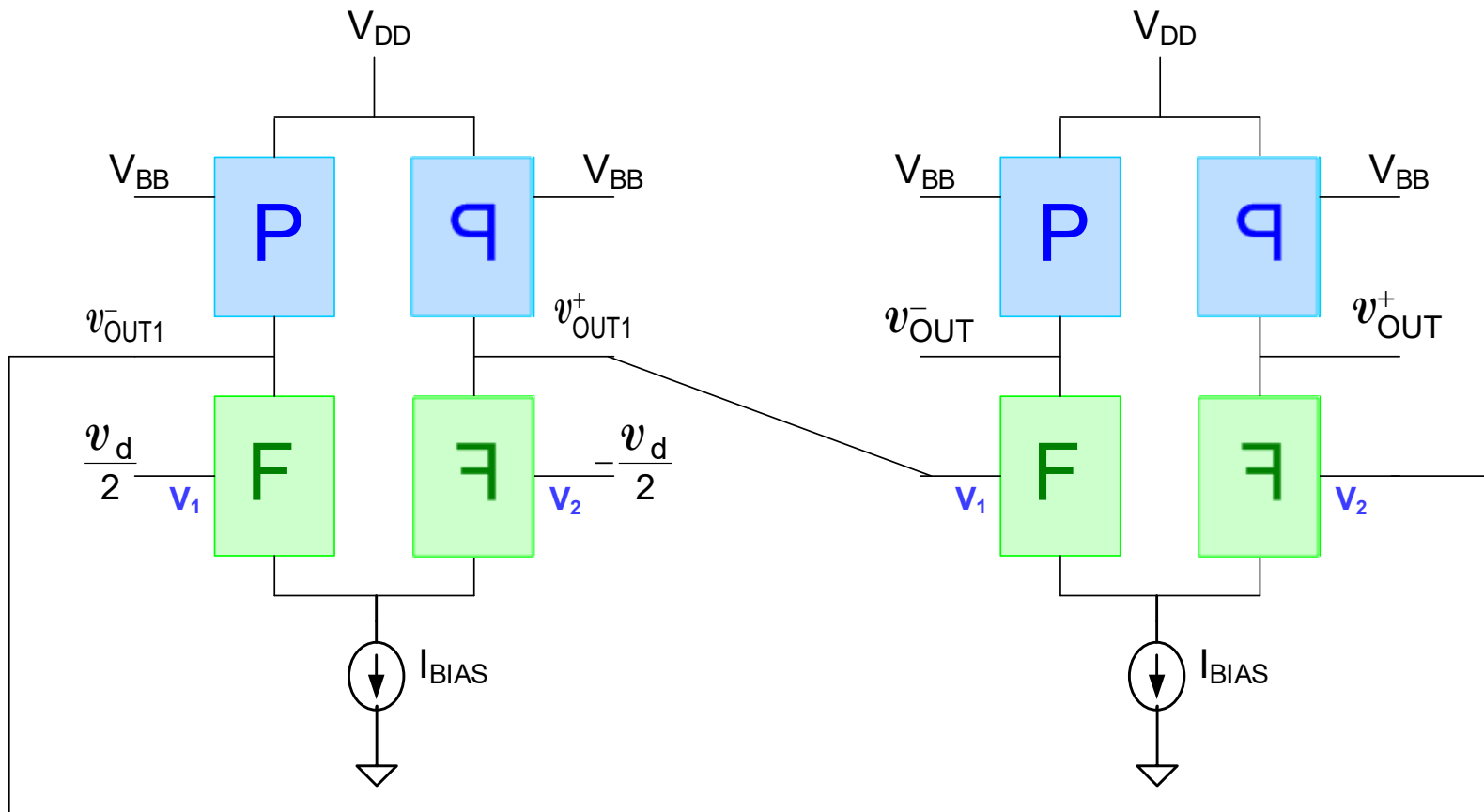

- Could be used but less popular

Two-stage op amp design

It is essential to know where the poles of the op amp are located since there are some rather strict requirements about the relative location of the open-loop poles when the op amp is used in a feedback configuration.

Parasitic Capacitances in MOS Devices

- Depletion region is formed between reverse-biased pn junctions
- Creates a capacitance C_{JUN}
- Voltage, area, and doping level dependent
- Can be quite large for large junctions

Depletion
Region

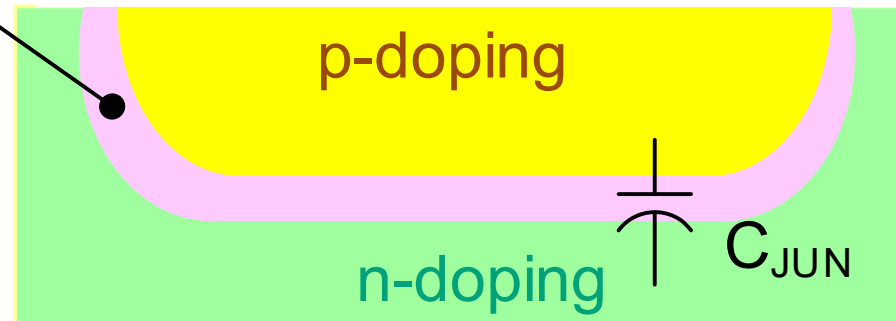

Parasitic Capacitances in MOS Devices

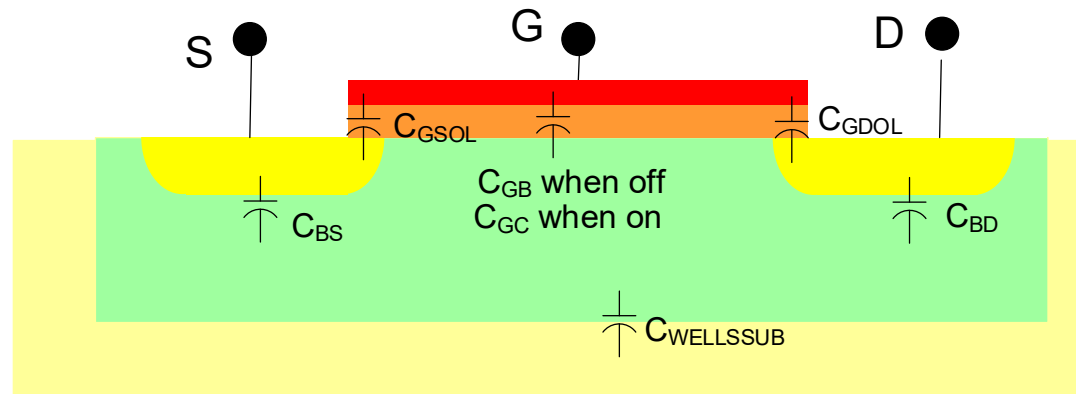
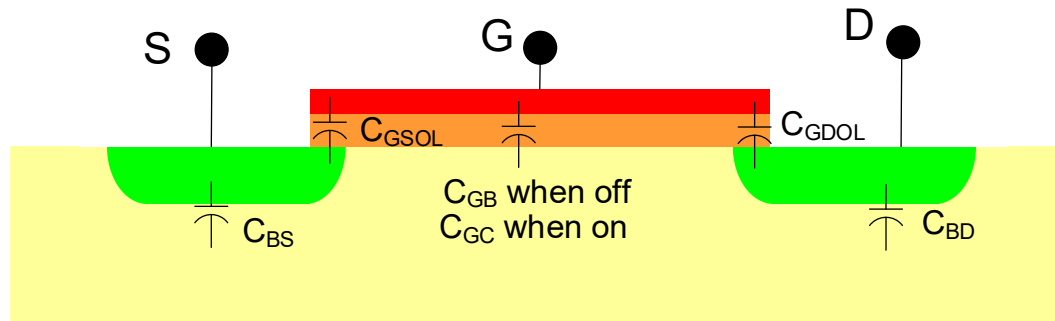

Parasitic Capacitances in MOS Devices

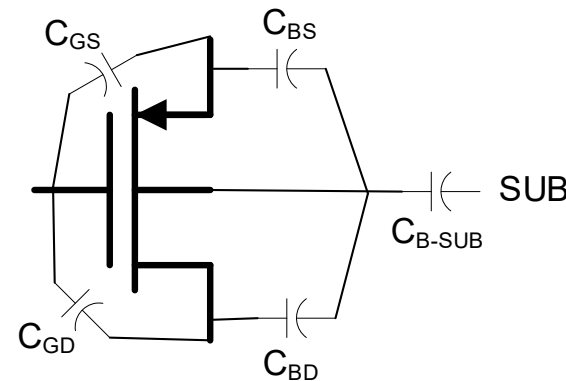
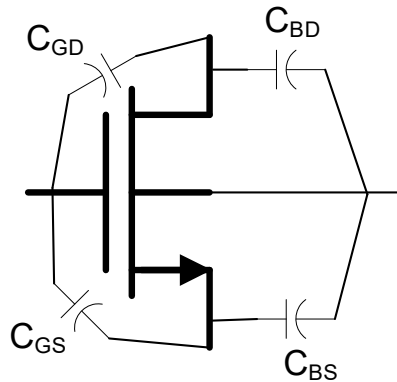
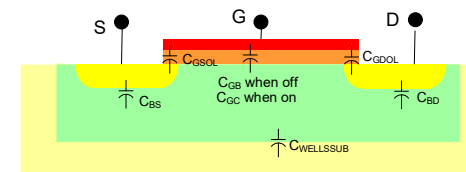
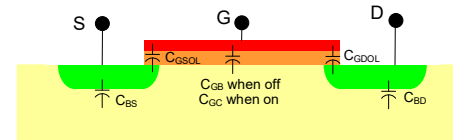

- Parasitic Capacitances added to Device Models
- C_{GS} is often largest
- C_{BD} and C_{BS} often quite large with large drain/source area

Poles and Zeros of Amplifiers

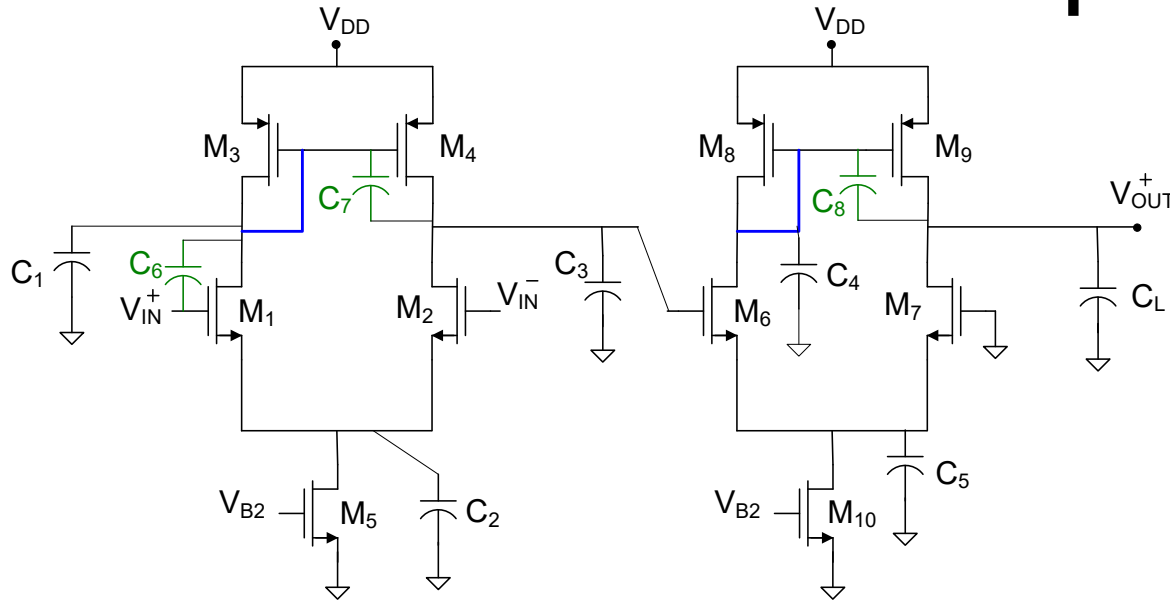

Cascaded Amplifier showing some of the capacitors

- There are a large number of parasitic capacitors in an amplifier (approx 5 for each transistor)
- Many will appear in parallel but the number of equivalent capacitors can still be large
- Order of transfer function is equal to the number of non-degenerate energy storage elements
- Obtaining the transfer function of a high-order network is a lot of work !
- Essentially every node in an amplifier has a capacitor to ground and these often dominate the frequency response of the amplifier (but not always)

Pole approximation methods

1. Consider all shunt capacitors
2. Decompose these into two sets, those that create low frequency poles and those that create high frequency poles (large capacitors create low frequency poles and small capacitors create high frequency poles)
 $\{C_{L1}, \dots, C_{Lk}\}$ and $\{C_{H1}, \dots, C_{Hm}\}$
3. To find the k low frequency poles, replace all independent voltage sources with ss shorts and all independent current sources with ss opens, all high-frequency capacitors with ss open circuits and, one at a time, select C_{Lh} and determine the impedance facing it, say R_{Lh} if all other low-frequency capacitors are replaced with ss short circuits. Then an approximation for the pole corresponding to C_{Lh} is

$$p_{Lh} = -1/(R_{Lh} C_{Lh})$$

4. To find the m high-frequency poles, replace all independent voltage sources with ss shorts and all independent current sources with ss opens, replace all low-frequency capacitors with ss short circuits and, one at a time, select C_{Hh} and determine the impedance facing it, say R_{Hh} if all other high-frequency capacitors are replaced with ss open circuits. Then the approximation for the pole corresponding to C_{Hh} is

$$p_{Hh} = -1/(R_{Hh} C_{Hh})$$

Pole approximation methods

These are just pole approximations but are often quite good

Provides closed-form analytical expressions for poles in terms of components of the network that can be managed during design

Provides considerable insight into what is affecting the frequency response of the amplifier

Pole approximation methods give no information about zero locations

Many authors refer to the “pole on a node” and this notation comes from the pole approximation method discussed on previous slide

Dominant low-frequency pole is largest of low-frequency poles and dominant high-frequency pole is smallest of high-frequency poles

Approach does a reasonable job of obtaining dominant low frequency poles (highest) and the dominant high frequency pole (lowest) if there is modest pole separation

Dominant low frequency and dominant high frequency poles are often most important

Example: Obtain the approximations to the poles of the following circuit

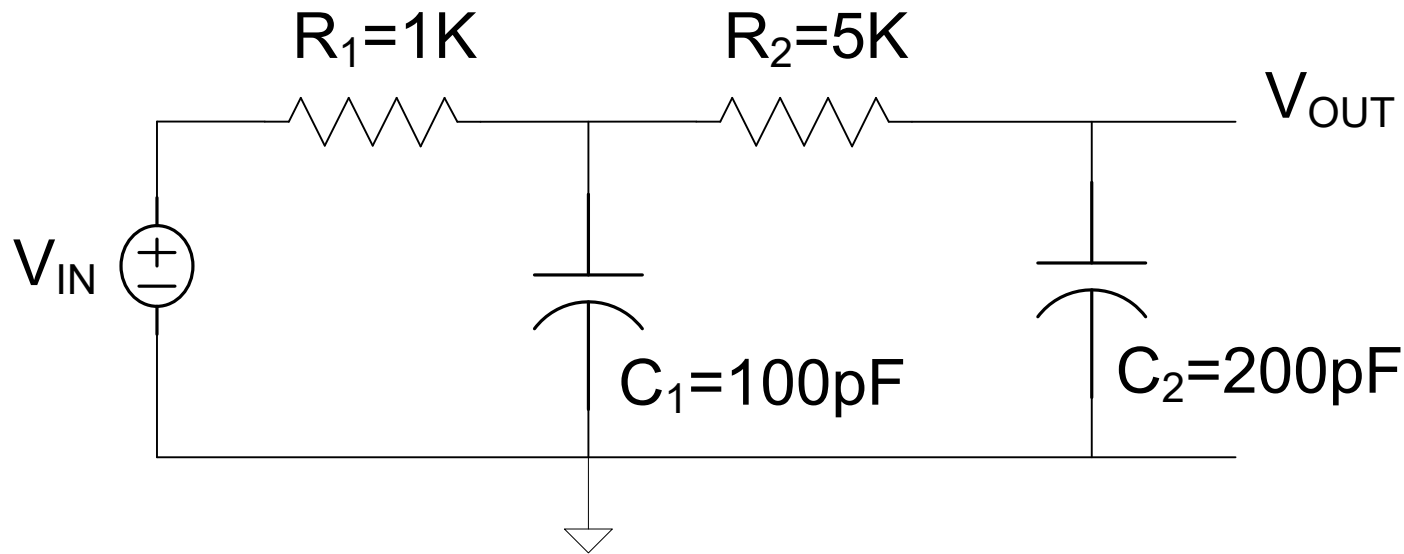

Since C_1 and C_2 are small, have two high-frequency poles

$\{C_1, C_2\}$

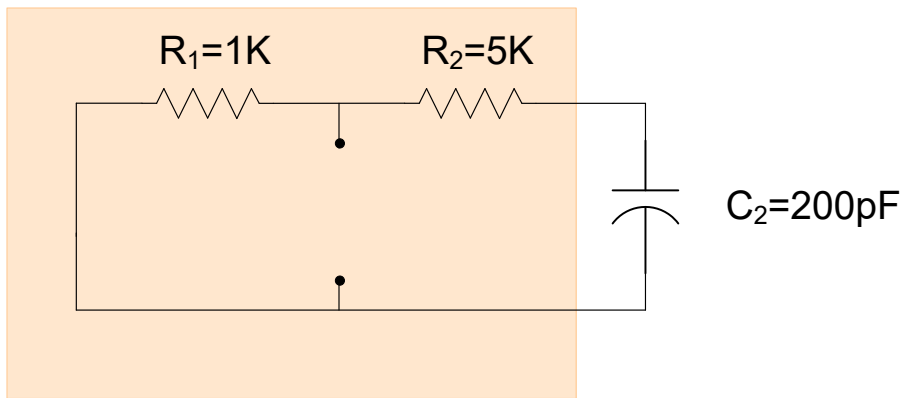
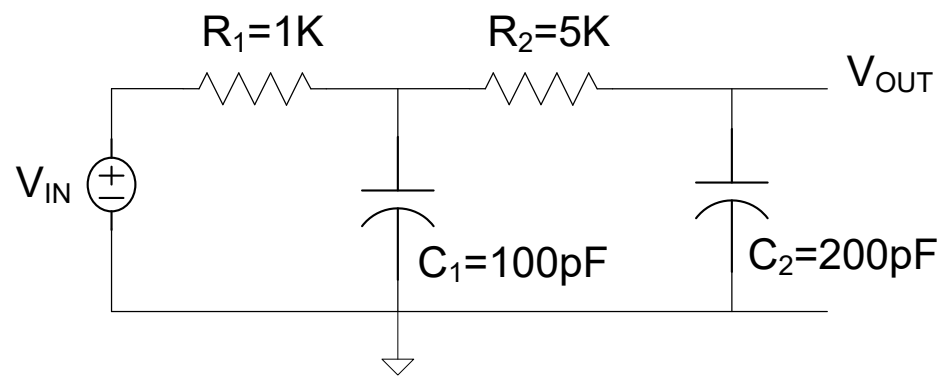

$$p_{H2} = - \frac{1}{C_2 (R_1 + R_2)}$$

$$p_{H2} = - 833Krad/sec$$

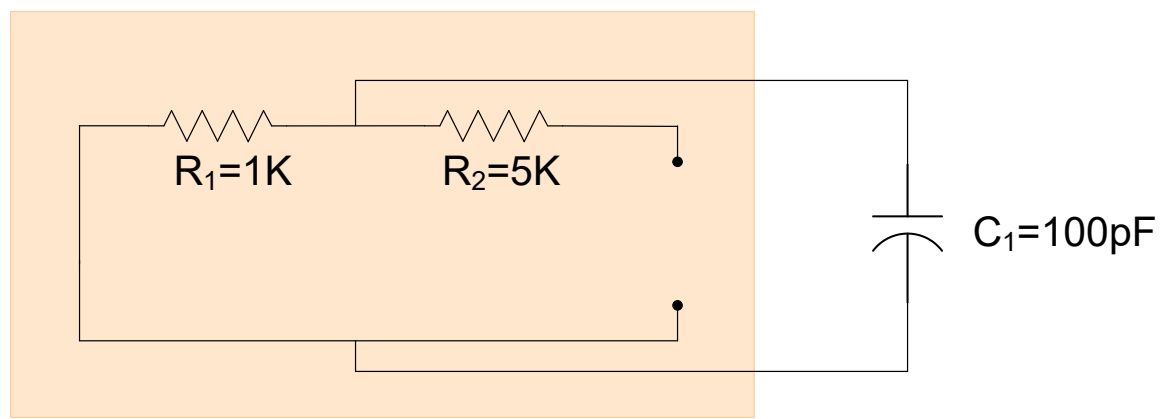

$$p_{H1} = - \frac{1}{C_1 R_1}$$

$$p_{H1} = -10M rad/sec$$

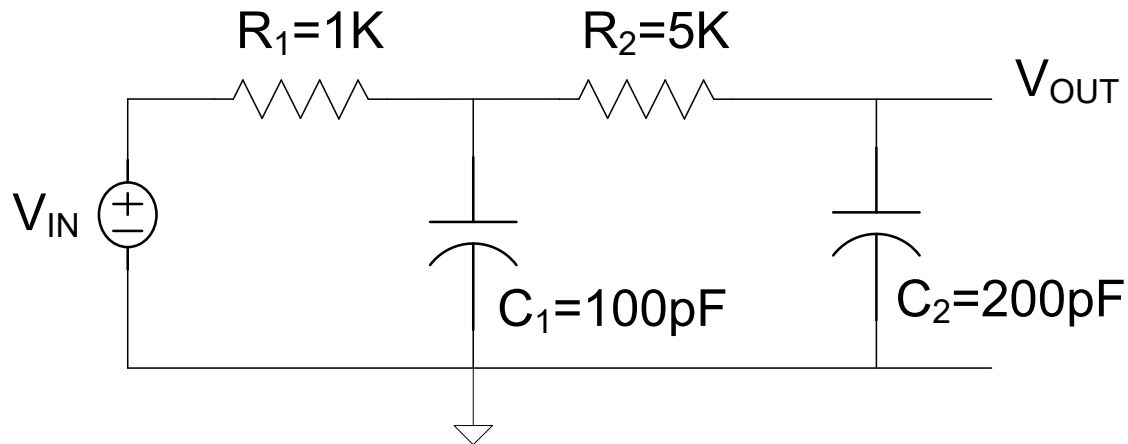

In this case, an exact solution is possible

$$T(s) = \frac{1}{R_1 R_2 C_1 C_2} \frac{1}{s^2 + \left[\frac{1}{R_1 C_1} + \frac{1}{R_2 C_2} + \frac{1}{R_2 C_1} \right] s + \frac{1}{R_1 R_2 C_1 C_2}}$$

$$p_{H1} = -12.2M \text{ rad/sec} \quad (18\% \text{ error})$$

$$p_{H2} = -821K \text{ rad/sec} \quad (1.4\% \text{ error})$$

Where we are at:

Amplifier Design

- Fundamental Amplifier Design Issues
- Single-Stage Low Gain Op Amps
- Single-Stage High Gain Op Amps
- Other Basic Gain Enhancement Approaches
 - Cascaded Amplifiers
(will return to this later)
- Two-Stage Op Amp
 -  – Compensation
 - Breaking the Loop
- Other Issues in Amplifier Design
- Summary Remarks

Compensation of Two-Stage Cascade

Definition

- “Compensation” is the modification of the op amp frequency response (that of the open-loop amplifier) so that acceptable ringing or overshoot or lack thereof in the closed-loop response is achieved
- Often do compensation for feedback amplifier applications though could compensate for closed-loop performance in other applications such as in a filter
- If two stages in cascade are first-order lowpass, compensation strategy is often to make an adequate pole spread to get acceptable closed-loop performance
- Often focus on the poles on the two nodes if cascade is of first-order lowpass stages
- If large spread of two poles that may inherently be close is required, can make one much larger or make one much smaller but fundamental speed limitations in a process often make it impossible to make one pole much larger so only alternative is often to make one pole much smaller

Note: Have intentionally not mentioned the term “stability” when discussing compensation

Compensation Concepts

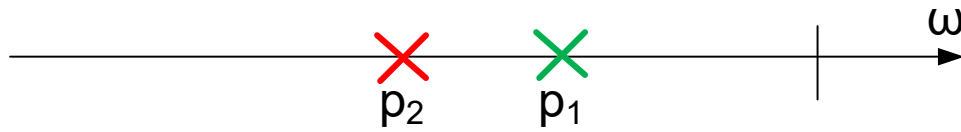

Original Pole Locations
Inadequate Separation

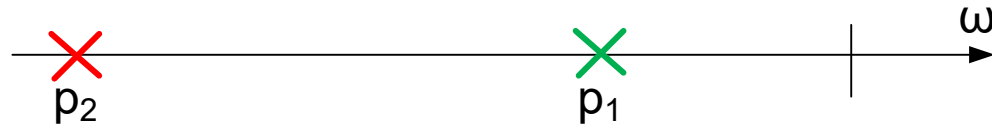

Technology Speed
Limitations

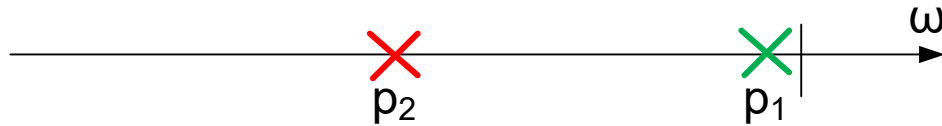

Most Widely Used Approach
(but dramatically slows circuit)

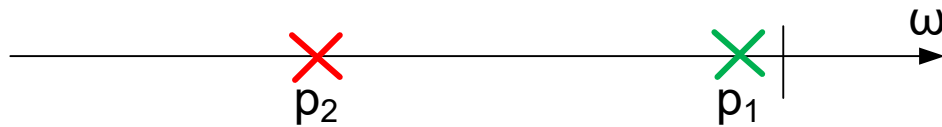

Modest left-movement of p_2
may be possible



Requires more pole
movement

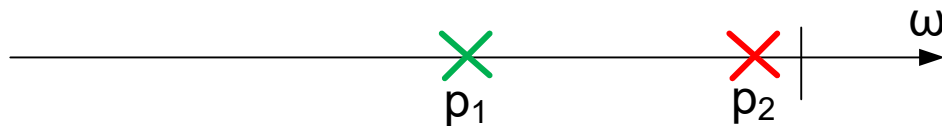

Modest left-movement of p_1
may be possible

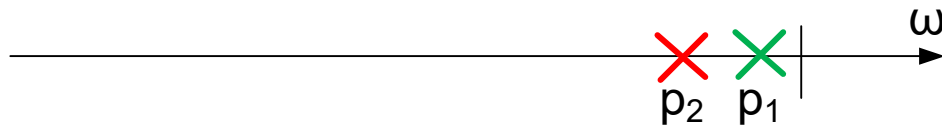

Will not provide
compensation!

Compensation of Basic Two-Stage Cascade

(shown for single input, single output but applicable to differential as well)

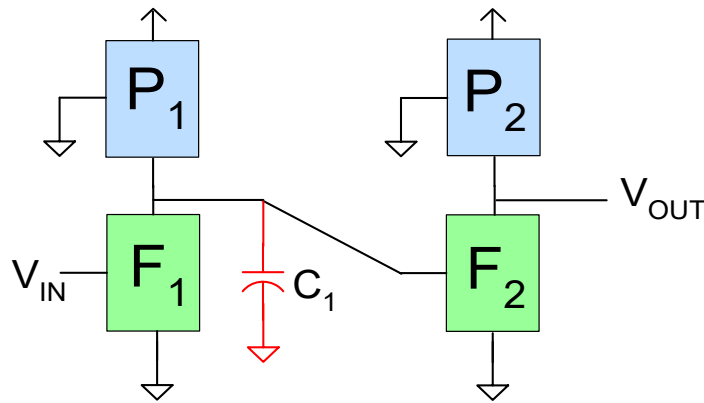

Internal Node Compensated

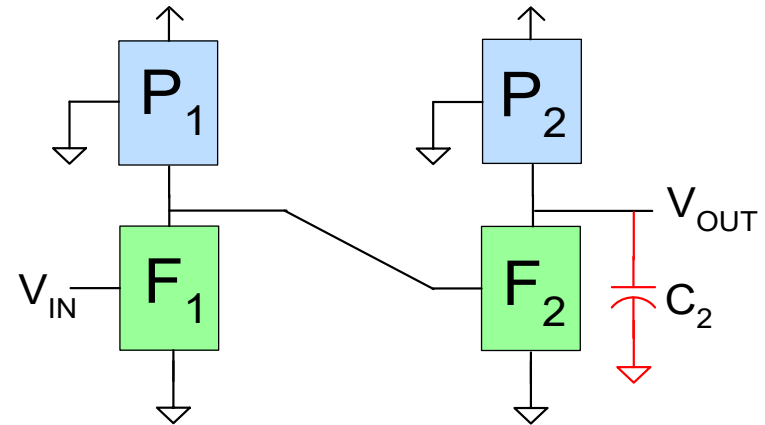

Output Compensated

- Modest variants of the compensation principle are often used
- Internal Node compensated creates the dominant pole on the internal node
- Output compensated creates the dominant pole on the external node
- Output compensated often termed “self-compensated”
- Internally Compensated denotes putting compensation circuit on-chip

Everything else is just details !!

Common Compensation Goal

Typical Target Closed-loop Pole Locations for Feedback Amplifiers

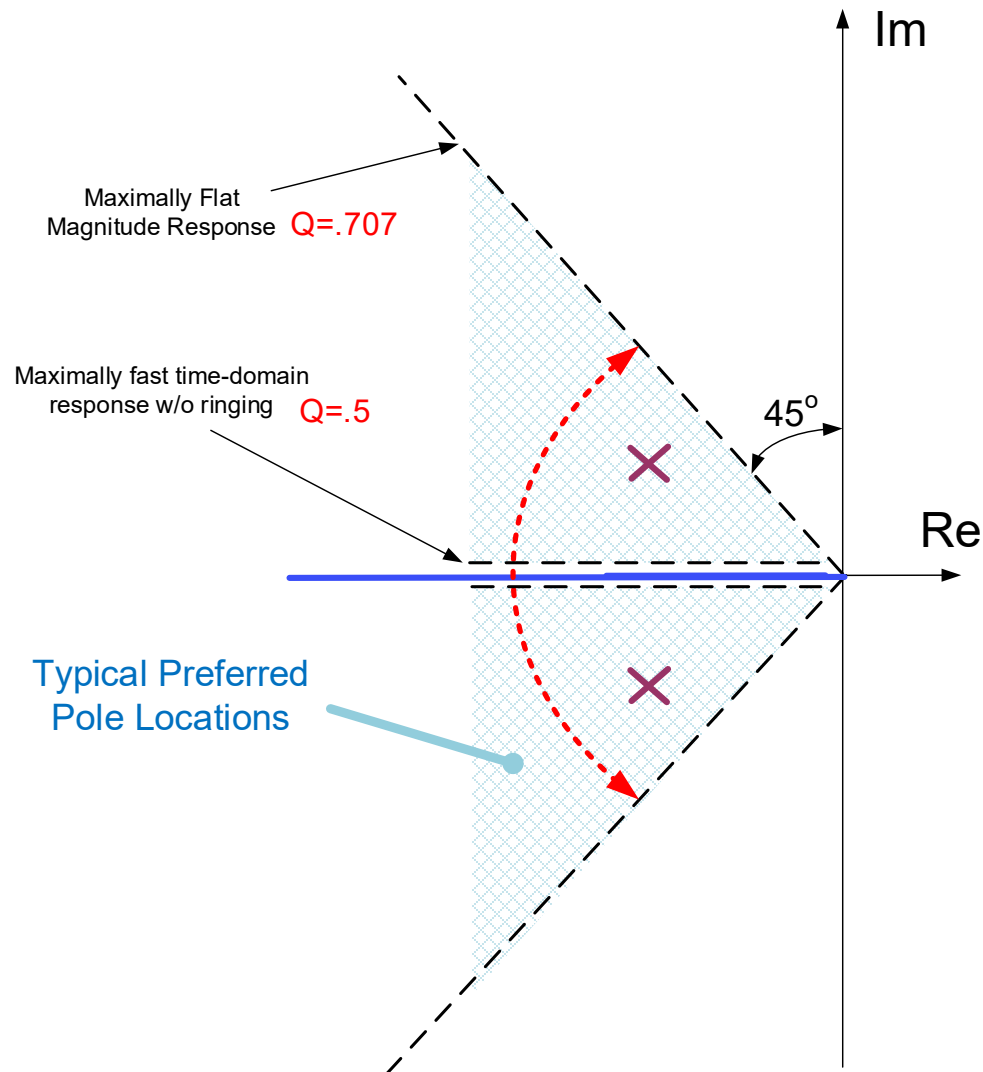

Compensation of Basic Two-Stage Cascade

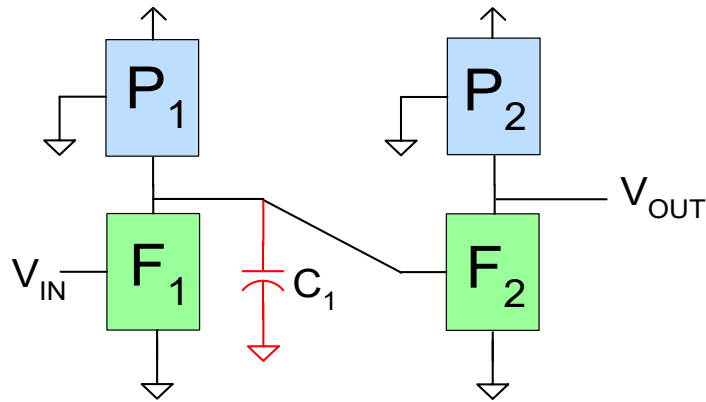

Internally Compensated

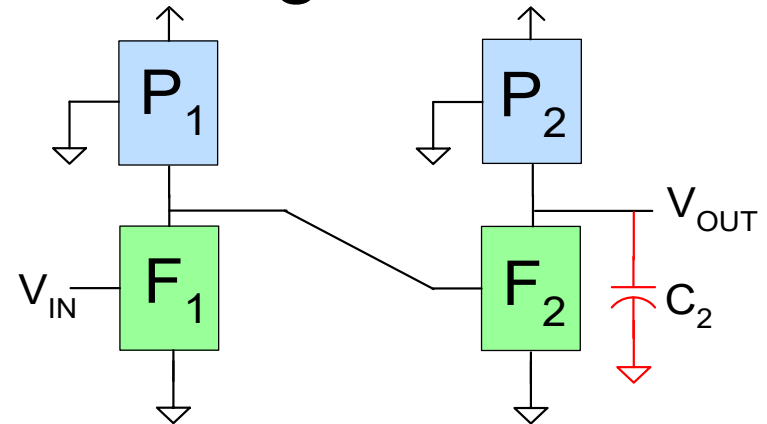

Output Compensated

Question: Would double compensation be even better?

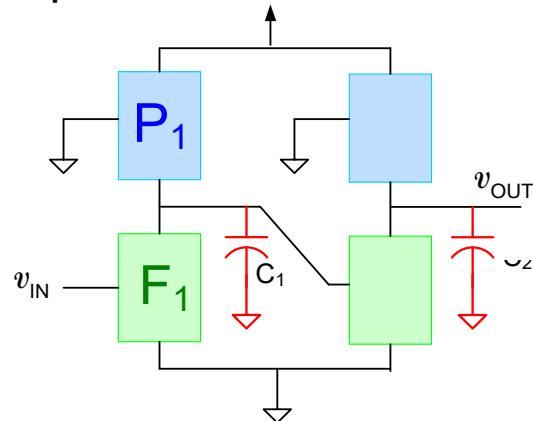

Double Compensated

No! A second compensation capacitor would move the open-loop poles back together !

Two-stage Architectural Choices

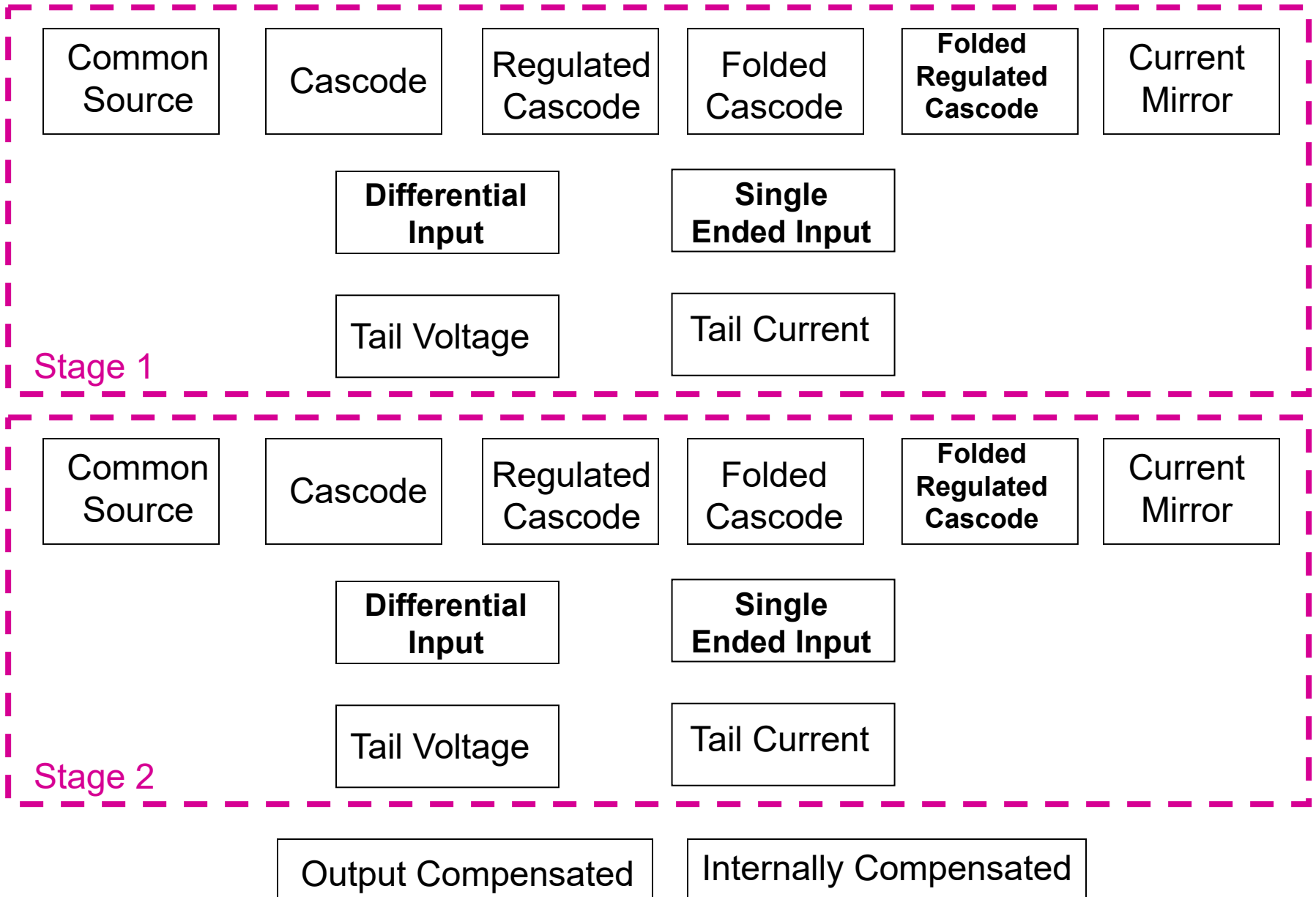

Two-stage Architectural Choices

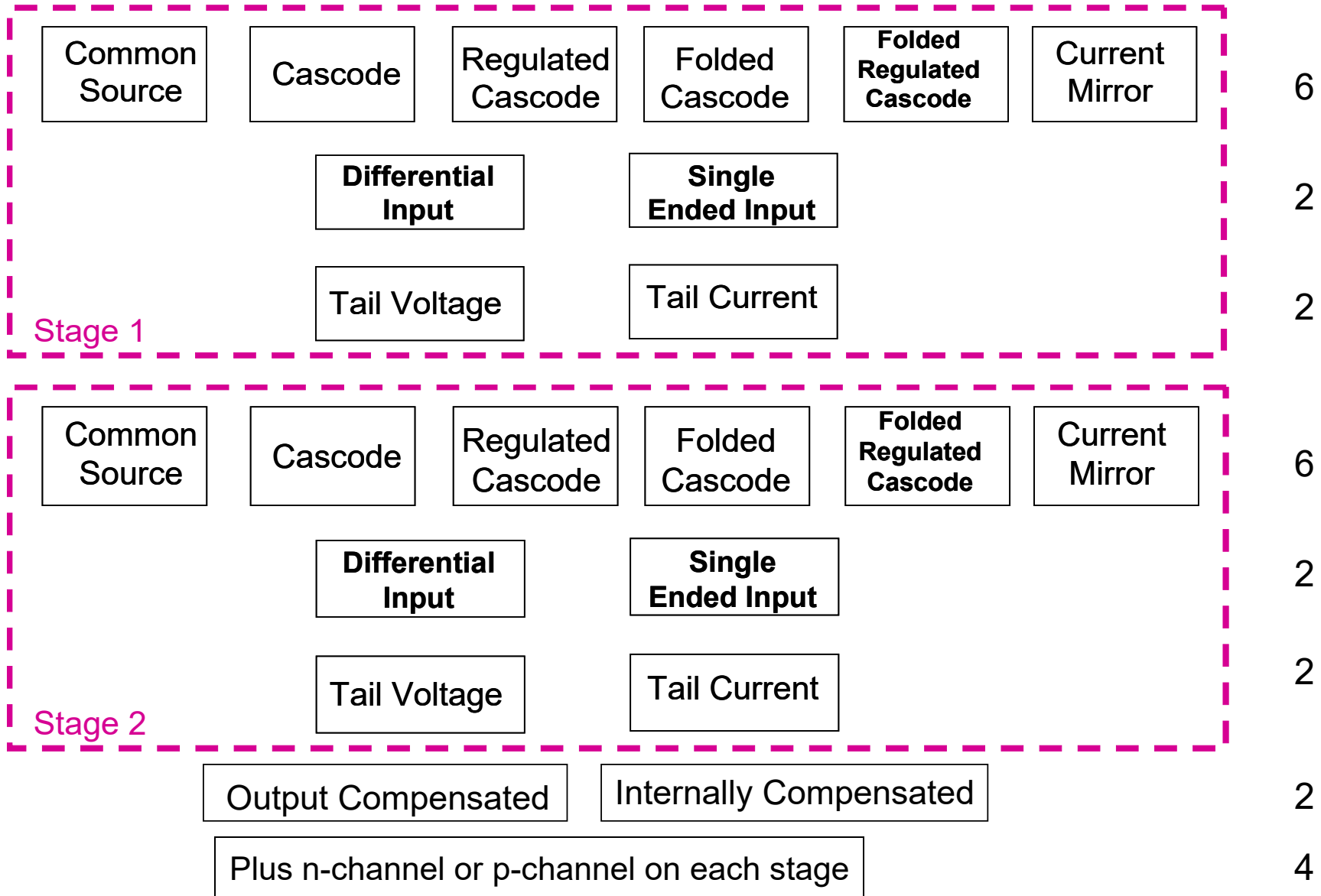

2304 Choices !!!

Two-stage Architectural Choices

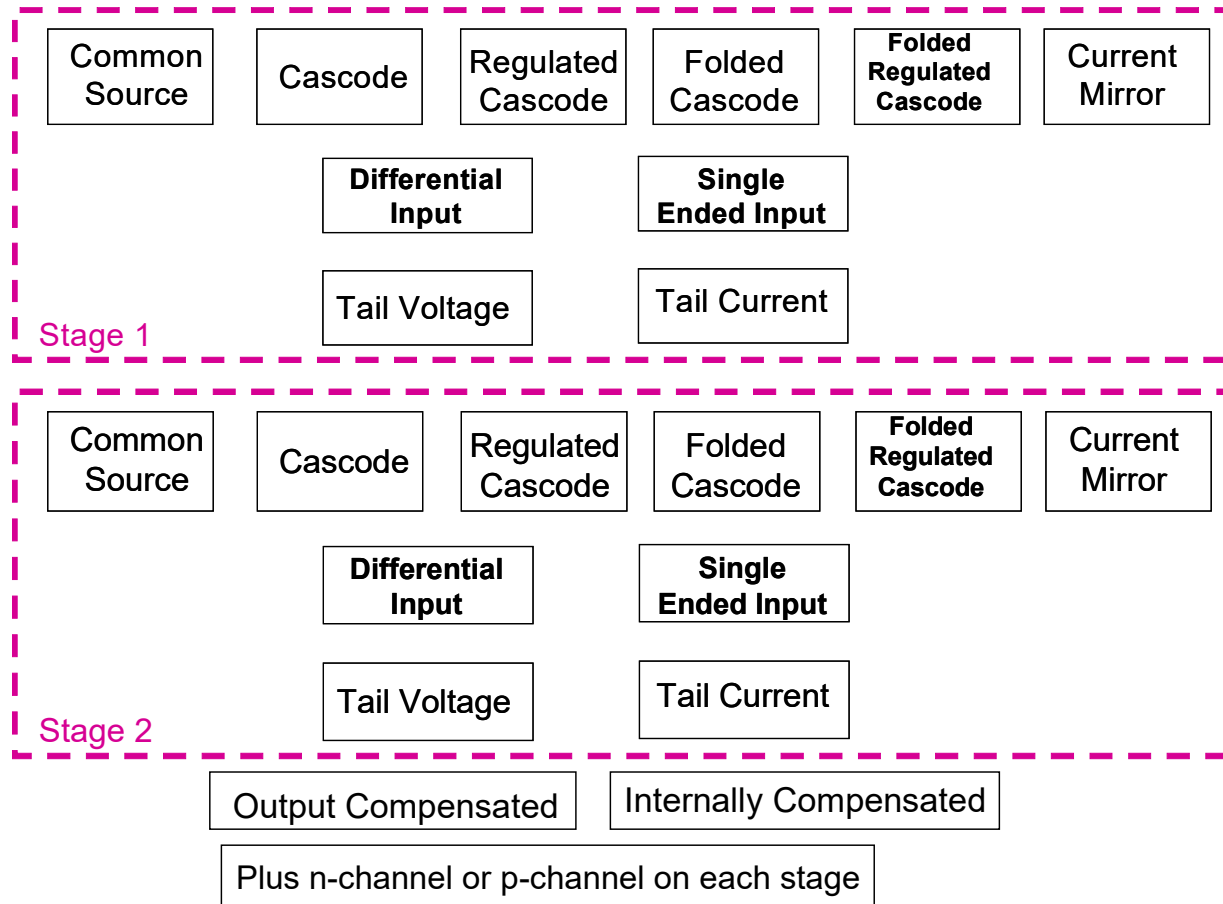

Which of these 2304 choices can be used to build a good op amp?

All of them !!



Stay Safe and Stay Healthy !

End of Lecture 13